

MANURE SPREADER N-221/3-3

TECHNICAL SPECIFICATIONS | EQUIPMENT



 **HOMOLOGATION
EUROPEAN**



 **CS LINE**



Year of model 2022

CynkoMet[®]
Czarna Białostocka

TECHNICAL SPECIFICATIONS	
Type / Variant / Version according to EU homologation	N-2 320 11
Administrative loading capacity	~5780 kg*
Technical loading capacity	~6,000 kg*
Gross vehicle weight rating according to PL regulations	9,800 kg
GVWR according to Directive 2015/208 (only load on axles)	7,300 kg
Unladen mass	~ 4,020 kg*
Number of axles	2 - tandem
Adapter	A4VS adapter - 4 vertical drums
Length	6,525 mm
Width	2,430 mm
Height	2,775 mm
Length of loading space ext. (góra)	4,300 mm
Width of loading box interior	2,070 / 2,150 mm
Height of loading box walls	800 mm
Height of platform from base	1,330 mm
Loading height	2,130 mm
Floor/wall sheet thickness	3/3 mm
Conveyor drive	Hydraulic lock
Adapter drive	Mechanical from the PTO shaft
Openable side walls	No
DETAILED SPECIFICATIONS	
Loading capacity (loading 5cm above the side walls)	7.2 m3
Track of wheels	1,700 mm
Suspension	Tandem - parabolic springs
Max. Drawbar eye load	2,500 kg
Drawbar coupling height - bottom position	390 mm
Drawbar coupling height - top position	1,030 mm
Max. tolerable axle load	1. 3,650 kg / 2 - 3,650 kg
Tyre size	400/60 15.5
Design speed	40 km/h
Minimum demand for tractor power	59kW/80KM
Spreading width depending on manure used	~6-8 m**

* - unladen mass and loading capacity may vary depending on equipment

** - spreading width may differ from the specified width depending on the material used

STANDARD MACHINE EQUIPMENT
Structural elements
Side walls bent with 1 sheet of sheet 3 mm with S355 steel with a height of 800 mm with walls stiffening profiles - hot-dip galvanised
A4VS adapter - 4 inclined vertical worm drums with bolted knives, with discs and lime board - hot-dip galvanised
Exchangeable floor made of hot-dip galvanised flat sheet
Two-position drawbar for coupling with the top or bottom hitch of the tractor, with replaceable 50 mm eye, drawbar homologated according to Regulation 55 UN ECE
Hydraulic advance of conveyor with stepless regulation and overload valve
Hot-dip galvanised hydraulic rear wall
Hot-dip galvanised adapter cover
Hot-dip galvanised front guard, meeting safety requirements
Bolted drawbar diam. 50
Top and bottom frame hot-dip galvanised (structure protected on exterior and interior of profiles)
Straight drawbar support with collapsible steel wheel, partially hot-dip galvanised
hot-dip galvanised conveyor chain, link diameter 11 mm
Replaceable hot-dip galvanised conveyor slats
Parking handbrake with crank
Hot-dip galvanised removable exterior ladder with anti-skid steps, facilitating access to the load box
Star wheels made of spheroidal graphite iron
EU homologation
Lighting installation connector cable with 7PIN 12V plug
12V lighting, homologated, with bulbs, LED perimeter lighting
Pneumatic two-line braking system with ALB
Hydraulic installations made of galvanised steel tubes and flexible hoses
Hydraulic connectors to tractor, type ISO 7241-1 DN 12.5
Chassis
New 400/60-15.5 wheels
Axles from renowned ADR company, full beam with 80 mm square cross-section, 300x60 brake

All of our agricultural machines are designed and tested by our design team using the latest available tools. Manufacturing is performed with the greatest diligence and in adherence to rigorous quality standards.

STANDARD MACHINE EQUIPMENT
Other elements
Two wheel chocks placed in galvanised pockets
articulated PTO shaft
Tandem suspension on parabolic leaf springs
Adapter drive protected by automatic clutch
Exchangeable adapter blades
Exchangeable, galvanised skids of floor conveyor strips
Distance between chains secures against divergence of chains during work
Wood skids for conveyor chains under upper frame
Hot-dip galvanised bracket for connectors, adjustable
Wall brackets equipped with reinforced edge seal preventing damage to walls' galvanised coating
Rear wall opening height indicator

OPTIONAL MACHINE EQUIPMENT
Structural elements
Hot-dip galvanised volume extensions with a hydraulic rear hatch - height 800 mm * (* it is not possible to mount the extensions together with the adapter)
Additional hydraulic distributor for tractors with two hydraulic outlets - hydraulic control of the rear wall, hydraulic drawbar support, on/off floor conveyor drive.
Hydraulic drawbar support
Deflector
Adapter blades made of high-strength steel
Adapter A2V - 2 vertical inclined screw drums with bolted knives, with plates and a counter for lime, with a deflector, hot-dip galvanised
Installations
Full LED lighting
Hydraulic quick-coupler with pressure neutralizer in hose
Homologated, hydraulic double-circuit brake system with automatic braking force adjustment
Chassis
Other equipment
Wide-angle articulated PTO shaft
Warning triangle
Digital control - conveyor drive control, rear wall, volume hatch, hydraulic drawbar support
Conveyor's hydraulic feed with electric control in tractor cabin
Hitch tension member K80

| Manure spreader N-221/3-3 | **6 TONS**

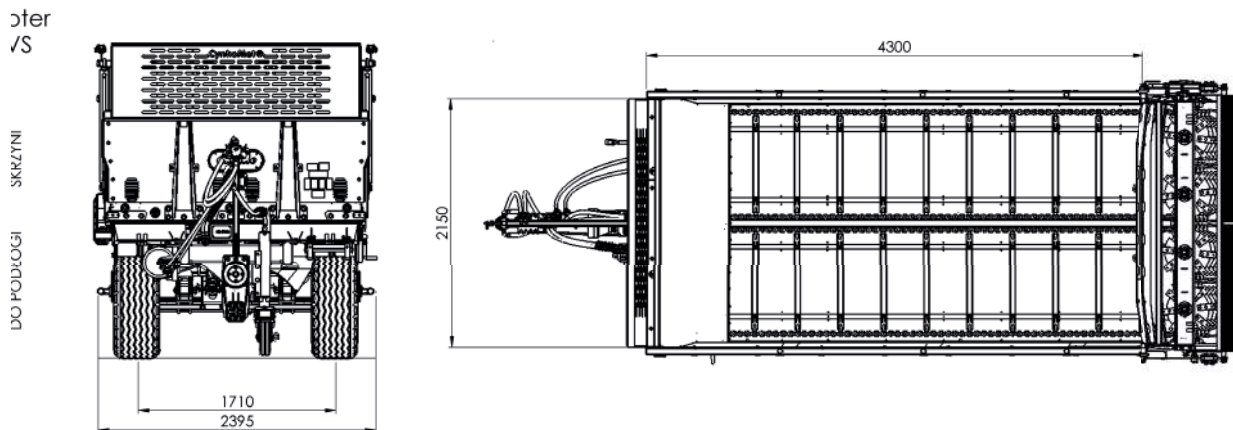
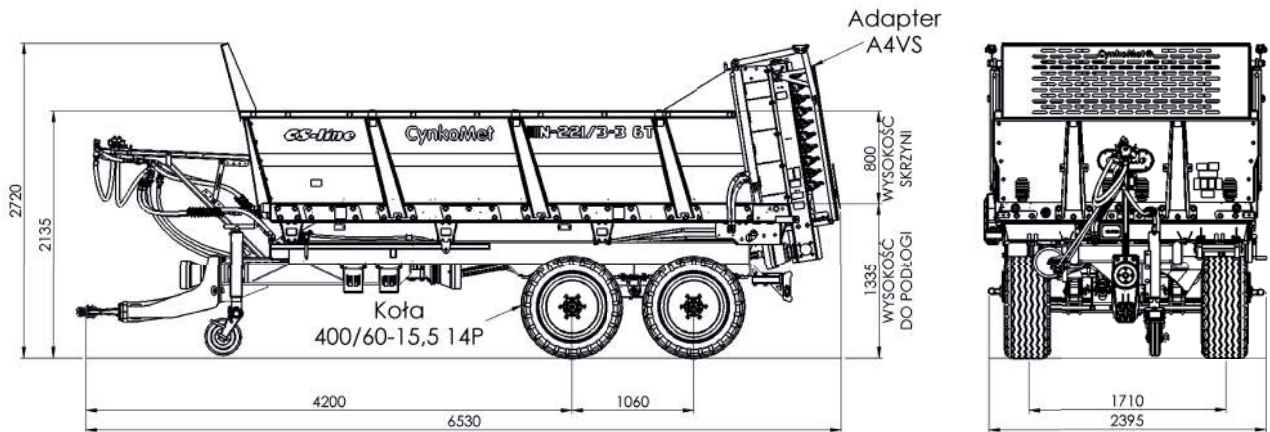

The data and photographs given in the catalogue are for illustrative purposes only. This document and the information it contains, including prices, do not constitute a commercial offer within the meaning of Article 66 of the Civil Code. This information may be subject to change as products are continuously improved. We reserve the right to change a product's characteristics at any time. Products' specifications may change without notice. Realization of an order begins when a person from our sales department confirms the data contained in the order form.



**HOT-DIP GALVANISED
CONSTRUCTION**