

# MANURE SPREADER N-221/3-3

TECHNICAL SPECIFICATIONS | EQUIPMENT



Year of model 2022

**CynkoMet**<sup>®</sup>  
Czarna Białostocka

<b>TECHNICAL SPECIFICATIONS</b>	
Administrative loading capacity	~6,000 kg*
Technical loading capacity	~6,000 kg*
Gross vehicle weight rating according to PL regulations	9,460 kg
Unladen mass	~ 3,460 kg*
Number of axles	2 - tandem
Adapter	A4VS adapter - 4 vertical drums
Length	6,540 mm
Width	2,395 mm
Height	2,650 mm
Length of loading space ext. (góra)	4,050 mm
Width of loading box interior	2,100 mm
Height of loading box walls	750 mm
Height of platform from base	1330 mm
Loading height	2,080 mm
Conveyor drive	Hydraulic lock
Adapter drive	Mechanical from the PTO shaft
Openable side walls	No
Floor/wall sheet thickness	3/2.5 mm
<b>DETAILED SPECIFICATIONS</b>	
Loading capacity (loading 5cm above the side walls)	7 m3
Track of wheels	1,700 mm
Suspension	Tandem - parabolic springs
Max. Vertical drawbar eye load	2,500 kg
Drawbar coupling height - bottom position	390 mm
Drawbar coupling height - top position	1,030 mm
Max. tolerable axle load	1. - 4,500 kg, 2. - 4,500 kg*
Tyre size	400/60-15.5
Design speed	30 km/h
Minimum demand for tractor power	59kW/80KM
Spreading width depending on manure used	~6-8 m**

\* - unladen mass and loading capacity may vary depending on equipment

\*\* - spreading width may differ from the specified width depending on the material used

<b>STANDARD MACHINE EQUIPMENT</b>
<b>Structural elements</b>
Wall height 750 mm - hot-dip galvanised
A4VS adapter - 4 inclined vertical worm drums with discs and lime board, hot-dip galvanised
Exchangeable floor made of hot-dip galvanised flat sheet
Two-position drawbar for coupling with the top or bottom hitch of the tractor, with replaceable 50 mm eye, drawbar homologated according to Regulation 55 UN ECE
Hydraulic advance of conveyor with stepless regulation and overload valve
Hot-dip galvanised hydraulic rear wall
Hot-dip galvanised adapter cover
Hot-dip galvanised front guard, meeting safety requirements
Bolted drawbar diam. 50
Top and bottom frame hot-dip galvanised (structure protected on exterior and interior of profiles)
Straight drawbar support with collapsible steel wheel, partially hot-dip galvanised
hot-dip galvanised conveyor chain, link diameter 11 mm
Replaceable hot-dip galvanised conveyor slats
Parking handbrake with crank
Exterior ladder with anti-skid steps, facilitating access to cargo box
Star wheels made of spheroidal graphite iron
<b>Installations</b>
Lighting installation connector cable with 7PIN 12V plug
12V lighting, homologated, rear bulb lamps, LED front lamps, perimeter reflectors
Two-line pneumatic brake system
Hydraulic installations made of galvanised steel tubes and flexible hoses
Hydraulic connectors to tractor, type ISO 7241-1 DN 12.5
<b>Chassis</b>
New 400/60-15.5 wheels
Axles from renowned ADR company, full beam with 80 mm square cross-section, 300x60 brake
<b>Other elements</b>
Two wheel chocks placed in galvanised pockets
Articulated shaft
Tandem suspension on parabolic leaf springs

*All of our agricultural machines are designed and tested by our design team using the latest available tools. Manufacturing is performed with the greatest diligence and in adherence to rigorous quality standards.*

**OPTIONAL MACHINE EQUIPMENT**

**Structural elements**

Hot-dip galvanised volume extensions with a hydraulic rear hatch - height 750 mm \* (\* it is not possible to mount the extensions together with the adapter)

Additional hydraulic distributor for tractors with two hydraulic sockets

Hydraulic drawbar support

Deflector

Installations

Full LED lighting

Hydraulic quick-coupler with pressure neutralizer in hose

Single-line pneumatic brake system

Single-line hydraulic brake system

Chassis

New 500/50-17 wheels

Other equipment

Wide-angle articulated shaft

Warning triangle

Digital control - conveyor drive control, rear wall, volume hatch, hydraulic drawbar support

Conveyor's hydraulic feed with electric control in tractor cabin

Hitch tension member K80

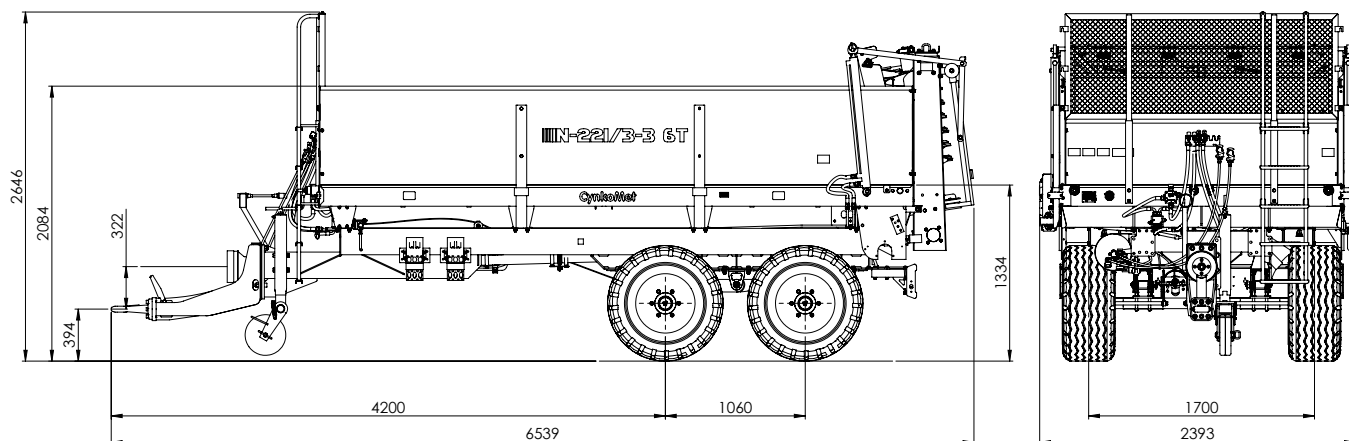

The data and photographs given in the catalogue are for illustrative purposes only. This document and the information it contains, including prices, do not constitute a commercial offer within the meaning of Article 66 of the Civil Code. This information may be subject to change as products are continuously improved. We reserve the right to change a product's characteristics at any time. Products' specifications may change without notice. Realization of an order begins when a person from our sales department confirms the data contained in the order form.



**HOT-DIP GALVANISED  
CONSTRUCTION**