

# Lime Attachment

TECHNICAL SPECIFICATIONS | EQUIPMENT



Year of model 2022

version.1.2022

**CynkoMet**<sup>®</sup>  
Czarna Białostocka

### TECHNICAL SPECIFICATIONS

Rotor revolutions	750 rpm
Unladen mass	~250 kg
Length	842 mm
Width	1,835 mm
Height	1,850 mm
Spreading range	~3.5 m
Maximum pressure	140 bar / 14 MPa
Maximum flow rate	60 l / min
Inter-operating adapter	A2HS

### STANDARD MACHINE EQUIPMENT

#### Structural elements

Two hydraulically-powered spreading plates with blades

12V lighting beam

Hot-dip galvanized plates, chutes to plates and plate guards

Adapter guard

Revolutions regulator

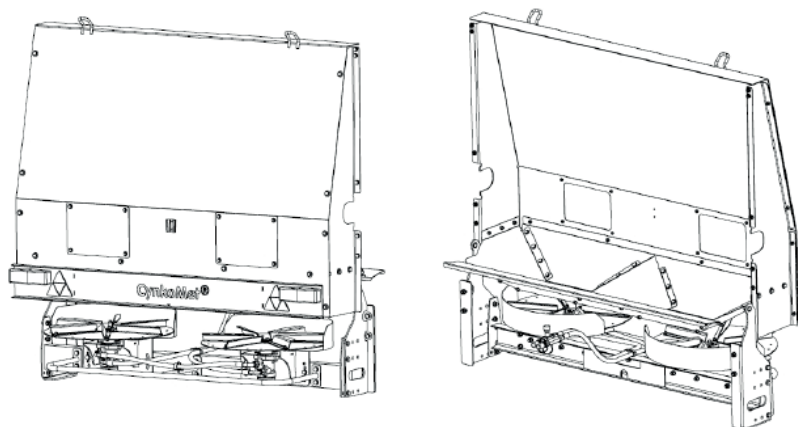

The data and photographs given in the catalog are for illustrative purposes only. This document and the information it contains, including prices, do not constitute a commercial offer within the meaning of art. 66 of the Civil Code. This information may be subject to change as products are continuously improved. The manufacturer reserves the right to change the product's characteristics at any time. Product specifications may change without prior notice.



**HOT-  
GALVANIZED CONSTRUCTION**